

# Pentair Sand filter fibreglass reinforced polyester 2" female thread 2,5bar blue type Triton® F-36S8-NEO-CP (7021213)



# TECHNICAL SPECIFICATIONS

Colour	blue
Material	fibreglass reinforced polyester
Connection	female thread
Pressure	2,5 bar
Max. temp.	50 °C
Type	Triton® F-36S8-NEO-CP
Capacity	32 m <sup>3</sup> /h
Gravel	100 kg
Size	2"
Diameter	914 mm
Weight	35.5 kg
Sand	300 kg
Filter area	0.64 m <sup>2</sup>
Max flow rate	32 m <sup>3</sup> /h
Max. pool vol.	160 m <sup>3</sup>

## DIMENSIONS

A 1160 mm

B 36 " inch

B 914 mm

C 738 mm

D 657 mm

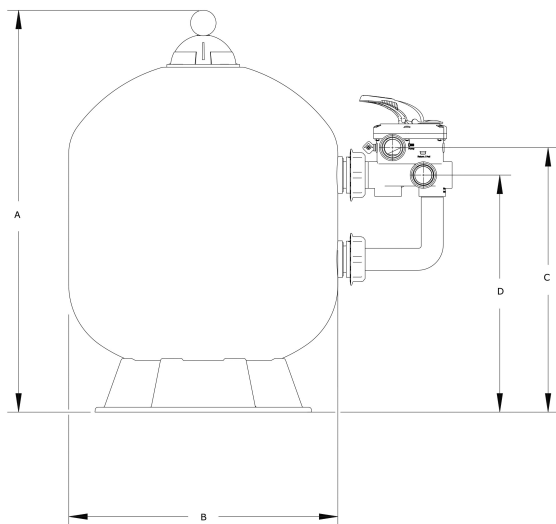

## PRODUCT INFORMATION

One-piece, fibreglass-reinforced tank with UV-resistant coating.

With side-mount 6-way valve.

Switch off the pump before each lever action.

Warranty period: Tank 10 years

**Last modified date: 25/05/2026**

Bosta UK Ltd.

Reflection House

Olding Road  
Bury St. Edmunds  
Suffolk  
IP33 3TA  
T +44 (0) 1284 716580  
E [enquiries@bosta.co.uk](mailto:enquiries@bosta.co.uk)  
<http://www.bosta.com>