

**Profec Swing check valve with
lifting device ductile iron
(GGG40) epoxy coating DN150
DIN flange 16bar DN150 blue
PN 10/16 (0402639)**



TECHNICAL SPECIFICATIONS

Colour	blue
Material	ductile iron (GGG40)
Surface treatment	epoxy coating
Material cover	ductile iron
Material housing	ductile iron (GGG40)
Material seal	NBR
Connection	DIN flange
Gasket	NBR
Temperature range	0°C - 80°C
Pressure	16 bar
Capacity	382 m ³ /h
Size	DN150
Length	400 mm
DN	150
Flange	PN 10/16
Outer ø	285 mm
PCD	240 mm

DIMENSIONS

Ct-1 143 mm

L 400 mm

PCD 240 mm

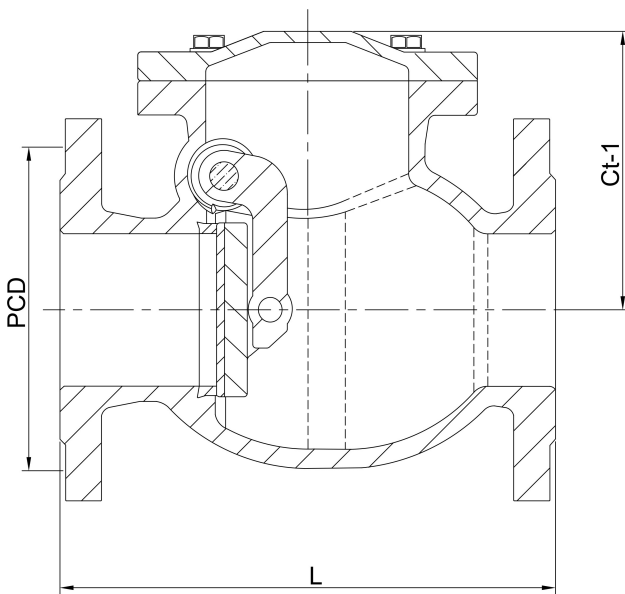

Last modified date: 23/05/2026

Bosta UK Ltd.
Reflection House
Olding Road
Bury St. Edmunds
Suffolk
IP33 3TA
T +44 (0) 1284 716580
E enquiries@bosta.co.uk
<http://www.bosta.com>