

**DAB High Flow centrifugal pool
pump fibreglass-reinforced PP
DN100 flange 8.8A 400VAC
black type Europro 550T
(7043311)**



TECHNICAL SPECIFICATIONS

Colour	black
Shaft	stainless steel 316
Pump body	fibreglass-reinforced PP
Material impeller 1	noryl
Material cover	fibreglass-reinforced PP
Material seal	stainless steel 316
Connection	flange
Voltage	400VAC
Max. temperature	40 °C
Frequency	50 Hz
Maximum ambient temperature 40 °C	
IP value	IP55
Motor RPM	1450
Type	Europro 550T
Capacity	140 m ³ /h
Output Power	5,33 HP
Max. head	14 m

Size DN100

Weight 53.5 kg

Power 4 kW

Ampere 8.8 A

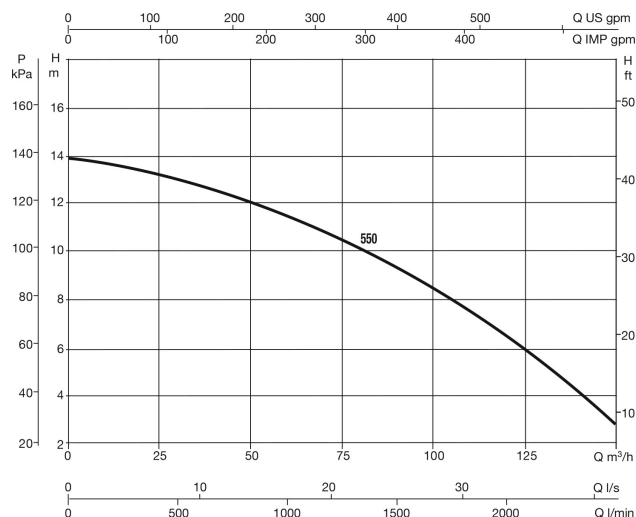
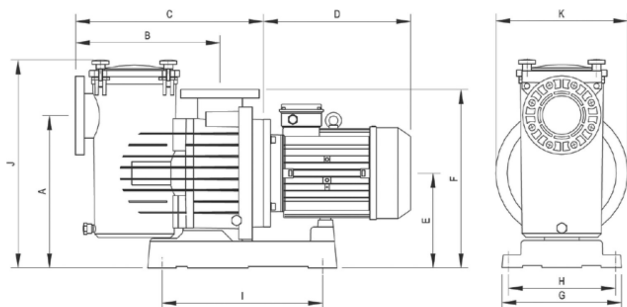

PRODUCT INFORMATION

High performance self-priming centrifugal electric pumps with built-in high capacity prefilter. 2 or 4 pole motor completely isolated from the water. Extremely quiet and highly reliable, developed for water circulation and filtration in large swimming pool filtration systems. Thanks to the AISI 316 mechanical seal, they are also suitable for specific applications for the circulation of sea water.

Last modified date: 27/05/2026

Bosta UK Ltd.
Reflection House
Olding Road
Bury St. Edmunds

Suffolk
IP33 3TA
T +44 (0) 1284 716580
E enquiries@bosta.co.uk
<http://www.bosta.com>