

Pentair Sand filter fibreglass reinforced polyester 1 1/2" female thread 2,5bar blue type Triton® F-24S8-NEO-CP (7021211)



TECHNICAL SPECIFICATIONS

| | |
|----------------|---------------------------------|
| Colour | blue |
| Material | fibreglass reinforced polyester |
| Connection | female thread |
| Pressure | 2,5 bar |
| Max. temp. | 50 °C |
| Type | Triton® F-24S8-NEO-CP |
| Capacity | 14 m ³ /h |
| Gravel | 50 kg |
| Size | 1 1/2" |
| Diameter | 610 mm |
| Weight | 18.4 kg |
| Sand | 100 kg |
| Filter area | 0.29 m ² |
| Max flow rate | 14 m ³ /h |
| Max. pool vol. | 70 m ³ |

DIMENSIONS

A 915 mm

B 24 " inch

B 610 mm

C 592 mm

D 530 mm

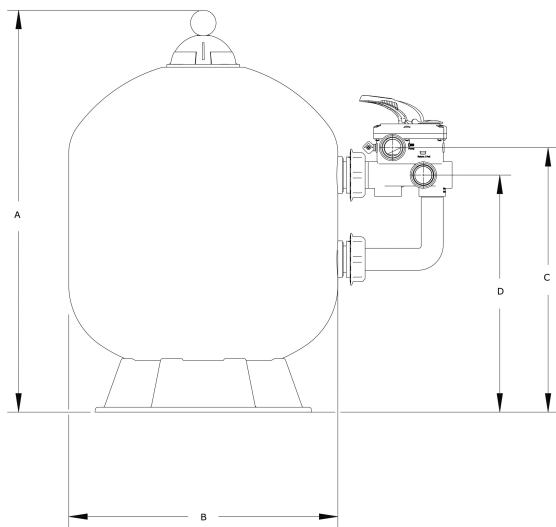

PRODUCT INFORMATION

One-piece, fibreglass-reinforced tank with UV-resistant coating.

With side-mount 6-way valve.

Switch off the pump before each lever action.

Warranty period: Tank 10 years

Last modified date: 25/05/2026

Bosta UK Ltd.

Reflection House

Olding Road
Bury St. Edmunds
Suffolk
IP33 3TA
T +44 (0) 1284 716580
E enquiries@bosta.co.uk
<http://www.bosta.com>