

Hydro-S Ball valve brass nickel plated 1/2" female thread 25bar (0470001)



hydro-s

TECHNICAL SPECIFICATIONS

Material brass

Surface treatment nickel plated

Operation lever

Colour lever blue

Handle material steel

Housing construction 2-part

Ball material hard chrome plated brass

Shaft brass

Material spindle brass

Material housing brass

Material seal PTFE

Connection female thread

Max. temperature 180 °C

Minimum medium temperature -20 °C
(continuous)

Temperature range -20°C - 120°C

Pressure 25 bar

Size 1/2"

Weight 13 kg

DIMENSIONS

Ct-1 46.9 mm

F-1 10 mm

F-2 10 mm

Handle height 445

Lb 46 mm

R 86 mm

ØDf 14 mm

ØDi-1 1/2 "

ØDi-2 1/2 "

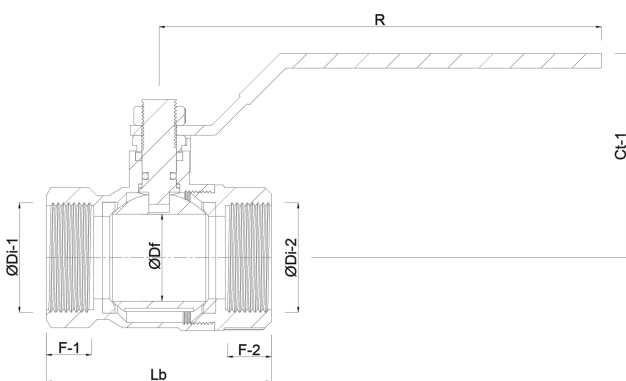

PRODUCT INFORMATION

The Hydro-S Ball valve is a cost efficient ball valve that is available with PTFE stem/ball seals. It is used by professionals for agricultural, heating and industrial projects. This reduced flow ball valve is made from brass which is known to be an environmental friendly solution as the recycling process of brass is less energy-intensive compared to aluminium and steel. It is available in a wide variety of sizes and with a 25 bar working pressure. Hydro-s is the brand of choice for professionals, looking for a cost efficient solution.

Last modified date: 23/05/2026

Bosta UK Ltd.
Reflection House
Olding Road
Bury St. Edmunds
Suffolk
IP33 3TA
T +44 (0) 1284 716580
E enquiries@bosta.co.uk
<http://www.bosta.com>