

PSH Pool pump polypropylene
1 1/2" female thread 1,9A
400VAC black type Mini 100T
(7032219)



 P S H

TECHNICAL SPECIFICATIONS

| | |
|---------------------|------------------------|
| Colour | black |
| Shaft | stainless steel 416 |
| Pump body | PP/GF30 |
| Material impeller 1 | noryl |
| Material cover | polycarbonate |
| Material seal | carbon/ceramic |
| Connection | female thread |
| Length | 487 mm |
| Max. temperature | 40 °C |
| Width | 194 mm |
| Height | 270 mm |
| Frequency | 50 Hz |
| IP value | IP55 |
| Motor RPM | 2900 |
| Type | Mini 100T |
| Capacity | 18,4 m ³ /h |
| Output Power | 1 HP |

Size 1 1/2"

Voltage 400VAC

Weight 12.2 kg

Power 0.75 kW

MWC 16

Ampere 1,9 A

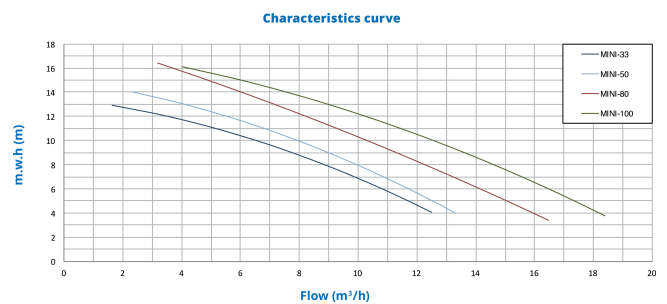
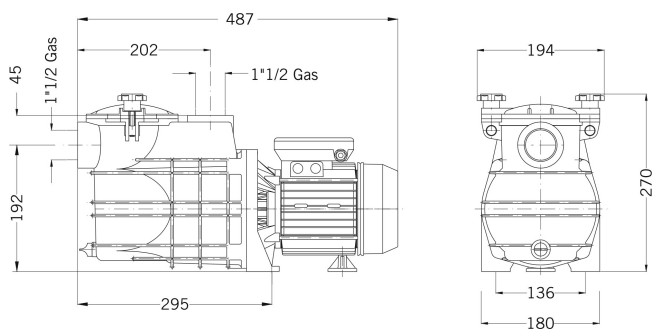

PRODUCT INFORMATION

Designed for small and medium size residential pools. The great self-priming capacity makes it the ideal pump for filtration and pool cleaners.

Features:

- Connection: female thread
- Self-priming up to 4mwh
- Suitable for operation with salt chlorinators and sea water up to 3,5% (35gr/l)
- High efficiency three phase motor class IE3 according to standard IEC 60034-30-1
- Thermal protection incorporated in single-phase version
- Supplied with 1,5m cable with Schuko plug in single-phase version
- Insulation Class: F
- Protection: IP55

- Motor: 50Hz/2900 rpm with option of 60Hz
- Max water temperature: 40°C

Last modified date: 10/03/2026

Bosta UK Ltd.
Reflection House
Olding Road
Bury St. Edmunds
Suffolk
IP33 3TA
T +44 (0) 1284 716580
E enquiries@bosta.co.uk
<http://www.bosta.com>