

**Profec Gate valve cast iron GG
25 powder coating DN100 DIN
flange 10bar black PN10/16
type 200/N (7036473)**



TECHNICAL SPECIFICATIONS

| | |
|-------------------------|-----------------|
| Colour | black |
| Type | 200/N |
| Material | cast iron GG 25 |
| Surface treatment | powder coating |
| Operation | handwheel |
| Colour lever | black |
| Handle material | cast iron |
| Material valve | cast iron |
| Material spindle | stainless steel |
| Seat material | brass |
| Material housing | cast iron GG 25 |
| Material seal | metal |
| Connection | DIN flange |
| Max. temperature | 100 °C |
| Flange according to DIN | DIN 2501/PN10 |
| Pressure | 10 bar |
| Size | DN100 |

Flange PN10/16

PCD 180 mm

Holes 8

DIMENSIONS

Construction length din 3352/2c/f4

Ct-1 353 mm

L 190 mm

L 190 mm

PCD 180 mm

R 200 mm

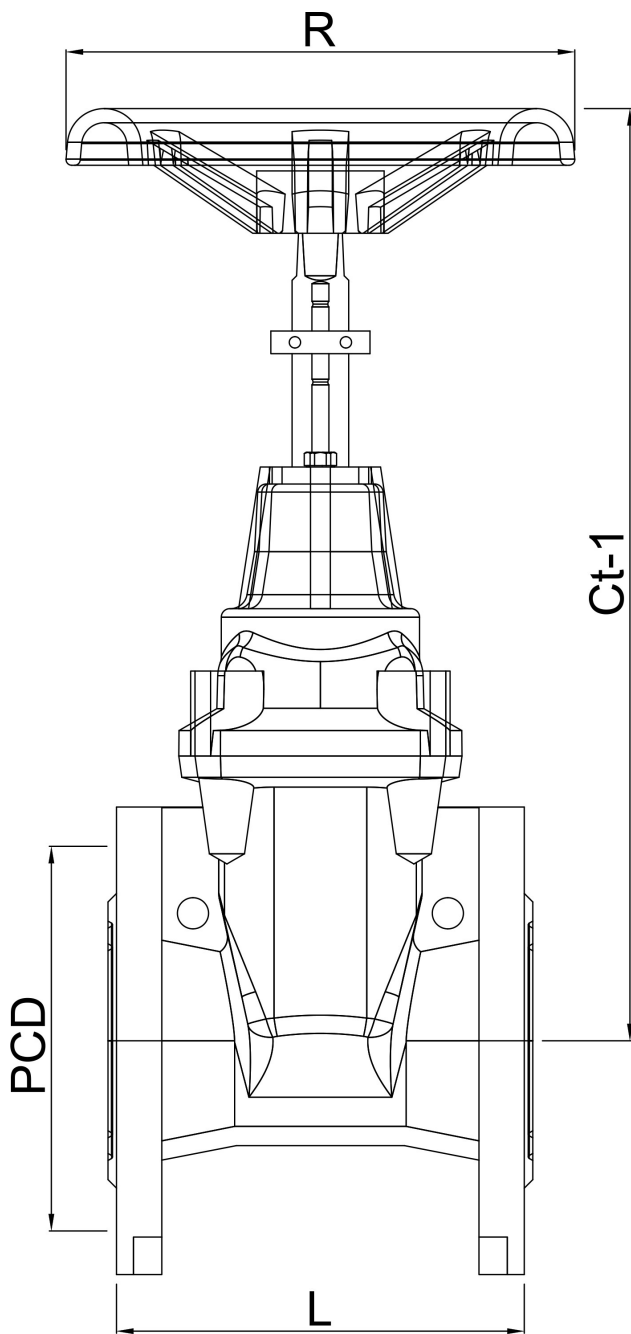

PRODUCT INFORMATION

Metal seated cast iron gate valve, non rising stem.

Last modified date: 27/05/2026

Bosta UK Ltd.
Reflection House
Olding Road
Bury St. Edmunds
Suffolk
IP33 3TA
T +44 (0) 1284 716580
E enquiries@bosta.co.uk
<http://www.bosta.com>